



## PM5100-T0

### GPON SFU with 2.5GbE LAN

The Zyxel PM5100-T0 GPON SFU comes with one 2.5GbE LAN port for the downlink interface. Service providers can optimize existing GPON network infrastructure while delivering premium services for subscribers with demands for reliable high-bandwidth and ultra-fast internet speeds.

### Benefits

#### Future-proof investment while service upgrade

Thanks to its superior interoperability, the PM5100-T0 can connect to any layer-3 devices such as routers, WiFi APs, and home gateways. Given the rapid evolution of WLAN technology and gateway interface requirements, service providers can always deliver premium services with cutting-edge technology without changing the entire fiber network infrastructure.

#### 2.5GbE LAN interface for optimal bandwidth utilization

Equipped with one 2.5GbE LAN port, the PM5100-T0 empowers service providers to fully utilize the existing GPON network while delivering premium services to meet the imperative demands for reliable, high-bandwidth.

#### Comprehensive QoS for superior network efficiency

Based on your service offerings to customers – you can freely define the QoS policies and prioritize mission-critical traffic. Defining the QoS will improve your customer's network efficiency and give them the super-fast multi-play service quality they want.



Gigabit data access via passive fiber



2.5G LAN port for optimized bandwidth utilization



Compact design for flexible deployment



Remote management via TR-069 and OMC1



Zyxel-developed OPAL for superior flexibility and faster time to market



Comprehensive QoS for network efficiency

## TR-069 remote management for lower OPEX

Supporting the TR-069 remote management specifications, the PM5100-T0 empowers service providers to process remote configuration, upgrade software, run diagnostics and provide management – all from customer support offices located anywhere. This greatly reduces service expenses, all while enhancing customer satisfaction.

## Zyxel OPAL firmware realizes the flexibility and faster time to market

Compliant with the same OPAL firmware trunk applied in all Zyxel CPEs, the PM5100-T0 inherits a field-proven feature set including TR-069 and more. Service providers can ensure the same user experience, after migrating to new devices.

## Specifications

### System specifications

#### GPON compliance

- Complies with ITU-T G.984
- DS/US speed: 2.488/1.244 Gbps
- Wavelength:  
1490 nm (DS) & 1310 nm (US)
- Complies with class B+ type PMD
- Physical distance reach to 20 km
- Dynamic Bandwidth Allocation (DBA)
- Configurable AES DS and FEC DS/US
- GPON Encapsulation Method (GEM) supports Ethernet packet
- Supports GEM header removal/insertion and data extraction/segmentation (GEM SAR)
- Supports up to 32 T-CONs each with priority queues (US); supports up to 256GEM ports
- Flexible mapping between T-CONT and GEM port

#### Layer 2 networking features

- MAC filtering
- Multicast transparent
- IPv6 address transparent

#### Multicast

- IGMP v1/v2/v3 snooping
- IPv6 MLD v1/v2 snooping

#### Feature capability

- VLAN IEEE 802.1Q
- Ethernet port based VLAN tag and untag
- Supports protocol based VLAN
- 1:1 VLAN, N:1 VLAN, VLAN transparent bridge

- LAN port-based VLAN tag add and tag removal
- Q in Q VLAN
- Supports at most 64 concurrent configurable VLANs with VLAN ID between 1 and 4095
- Supports up to 2K MAC address entries

#### QoS

- Traffic classification and tagging via DSCP/VLAN/802.1P-bit
- Gem port rate limitation for US/DS traffic
- Per-port QoS and CoS mapping according to IEEE 802.1q and IEEE 802.1p priority
- SP/WRR/SP+WRR

#### Security

- MAC filtering

#### Management

- Standard OMCI (ITU-T G.988)/TR-069
- Web GUI (HTTP/HTTPS)

### Hardware specifications

- WAN: One GPON uplink with SC/APC connector
- LAN: One 100M/1G/2.5G Gbps RJ-45 port
- Reset: one reset/restore factory default button
- Power switch: one push type button
- LEDs indicators:
  - Power
  - PON
  - LOS
  - LAN
- Power supply: 12 V DC/1 A

### Power consumption

- 12 Watt max

### Physical specifications

- Item dimensions (WxDxH):  
130 x 120 x 32 mm  
(5.11" x 4.72" x 1.26")
- Item weight: 198 g (0.44 lb.)
- Packing dimensions (WxDxH):  
260 x 140 x 40 mm  
(10.24" x 5.51" x 1.57")
- Packing weight: 381 g (0.84 lb.)

### Environmental specifications

#### Operating environment

- Temperature:  
0°C to 40°C (32°F to 104°F)
- Humidity:  
10% to 90% RH (non-condensing)

#### Storage environment

- Temperature:  
-30°C to 70°C (-22°F to 158°F)
- Humidity:  
10% to 95% RH (non-condensing)

### Certification

- EMC: CE
- Safety: CE LVD
- Energy saving: ErP

### Package contents

- Device
- Power adaptor
- Ethernet cable
- Safety warning & DoC letter
- Quick start guide

## Application diagram

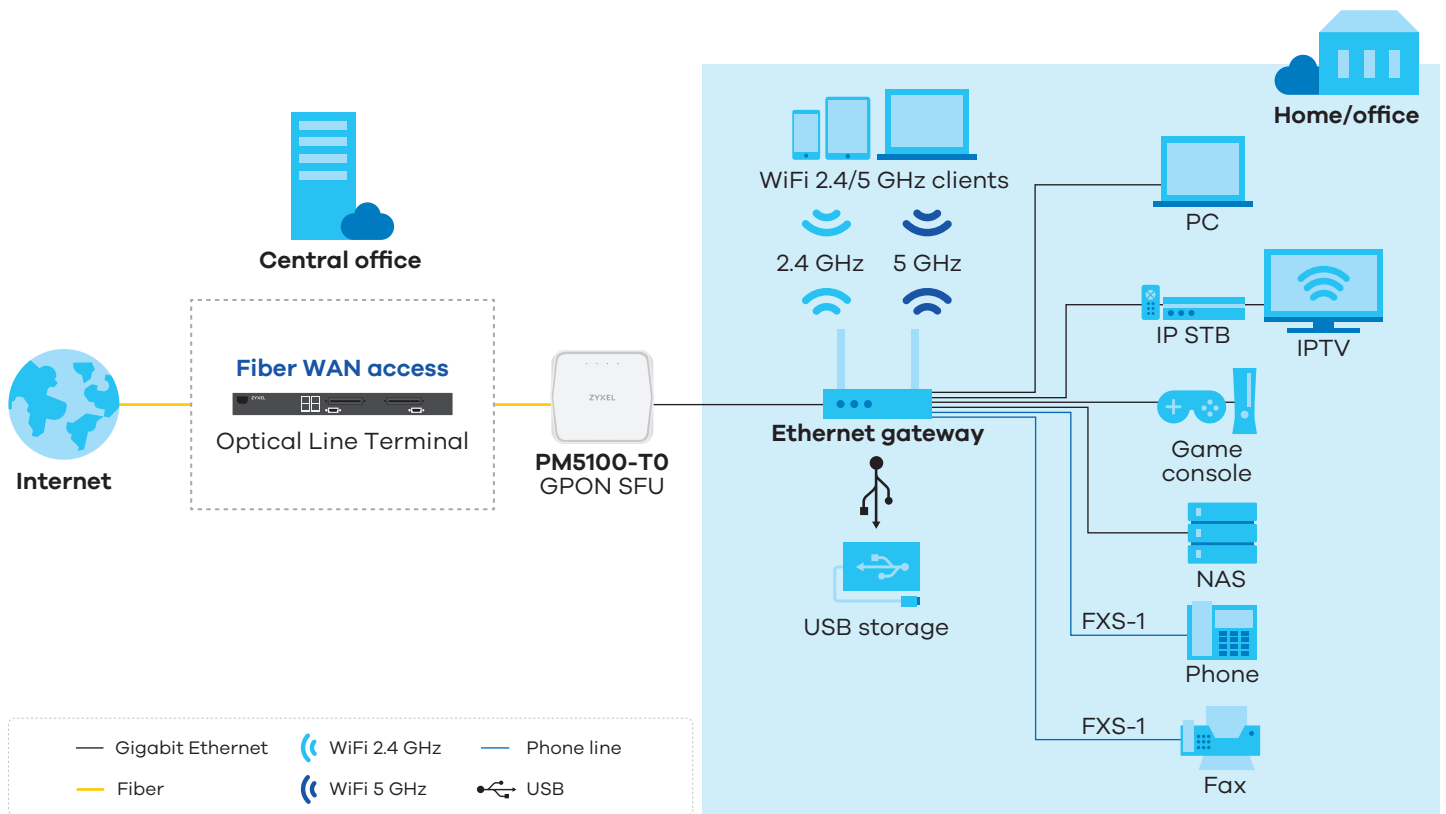

## Hardware description

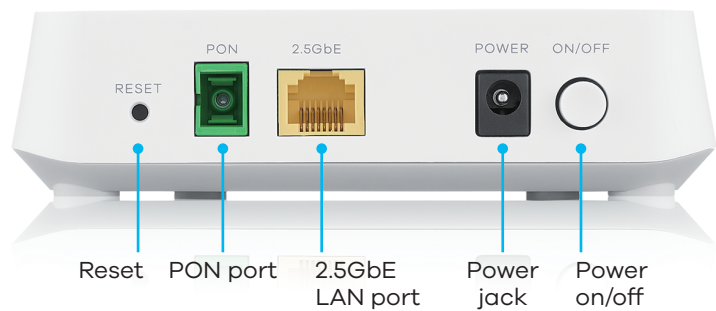



For more product information, visit us on the web at <https://service-provider.zyxel.com>

Copyright © 2021 Zyxel and/or its affiliates. All rights reserved.  
All specifications are subject to change without notice.



17/12/21

Datasheet [PM5100-T0](#)