



Huawei CloudEngine 6881 Switch Datasheet

Huawei CloudEngine 6881 series switches have advanced hardware architecture with 40GE/100GE uplink ports and high-density 10GE access ports.

CloudEngine 6881 series can be used to build a scalable data center network platform in the cloud computing era, or work as core or aggregation switches on campus networks.

Product Overview

Huawei CloudEngine 6881 series switches are next-generation 10GE access switches that provide high performance and high port density on data center networks and high-end campus networks. The CloudEngine 6881 series have advanced hardware architecture with 40GE/100GE uplink ports and high-density 10GE access ports. Using Huawei's VRP8 software platform, CloudEngine 6881 series switches support extensive data center features and high stacking capabilities. In addition, the CloudEngine 6881 series use a flexible airflow design (front-to-back or back-to-front). CloudEngine 6881 series can work with CloudEngine 16800 or CloudEngine 12800 series data center core switches to build elastic, virtual, and high-quality 40GE/100GE full-mesh networks, meeting requirements of cloud computing data centers.

CloudEngine 6881 series provide high-density 10GE access to help enterprises and carriers build a scalable data center network platform in the cloud computing era. They can also work as core or aggregation switches on campus networks.

Product Appearance

CloudEngine 6881-48S6CQ series switches provide 48 x 10GE SFP+ ports , 6 x 100GE QSFP28 ports.

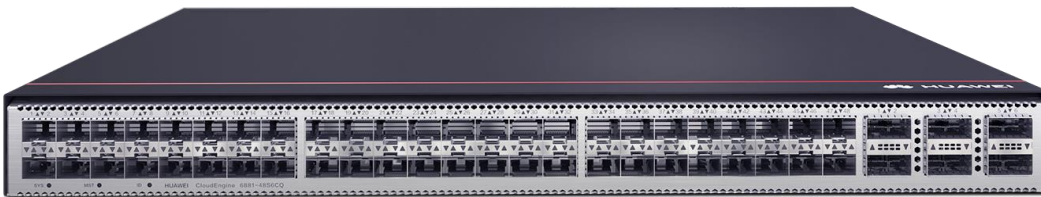

CloudEngine 6881-48T6CQ series switches provide 48 x 10GE Base-T ports , 6 x 100GE QSFP28 ports.



Product Characteristics

High-Density Access

- CloudEngine 6881 series provide up to 48 x 10GE ports, allowing for high-density 10GE server access and smooth evolution.
- CloudEngine 6881 series provide up to 6 x 100GE QSFP28 ports. Each QSFP28 port can also be used as one 40GE QSFP+ port, providing flexibility in networking. The uplink 40GE/100GE ports can be connected to CloudEngine 16800 or CloudEngine 12800 series switches to build a non-blocking network platform.

Inter-device Link Aggregation, High Efficiency and Reliability

- CloudEngine 6881 series support multi-chassis link aggregation group (M-LAG), which enables links of multiple switches to aggregate into one to implement device-level link backup.
- Switches in an M-LAG system all work in active state to share traffic and back up each other, enhancing system reliability.
- Switches in an M-LAG system can be upgraded independently. During the upgrade, other switches in the system take over traffic forwarding to ensure uninterrupted services.
- M-LAG supports dual-homing to Ethernet, VXLAN, and IP networks, allowing for flexible networking.

Virtualized Hardware Gateway, Enabling Quick Deployment

- CloudEngine 6881 series can connect to a cloud platform through open APIs, facilitating the unified management of virtual and physical networks.
- CloudEngine 6881 series can work with the industry's mainstream virtualization platforms. The virtualization function protects investments by ensuring services can be deployed quickly without requiring network changes.

- The hardware gateway deployment enables fast service deployment without changing the customer network, providing investment protection.
- CloudEngine 6881 series support Border Gateway Protocol - Ethernet VPN (BGP-EVPN), which can run as the VXLAN control plane to simplify VXLAN configuration within and between data centers.

Standard Interfaces, Enabling Openness and Interoperability

- CloudEngine 6881 series support NETCONF and can work with Huawei iMaster NCE-Fabric.
- CloudEngine 6881 series support Ansible-based automatic configuration and open-source module release, expanding network functions and simplifying device management and maintenance.
- CloudEngine 6881 series can be integrated into mainstream SDN and cloud computing platforms flexibly and quickly.

ZTP, Implementing Automatic O&M

- CloudEngine 6881 series support Zero Touch Provisioning (ZTP). ZTP enables the CloudEngine 6881 series to automatically obtain and load version files from a USB flash drive or file server, freeing network engineers from onsite configuration and deployment. ZTP reduces labor costs and improves device deployment efficiency.
- ZTP provides built-in scripts through open APIs. Data center personnel can use a programming language they are familiar with, such as Python, to centrally configure network devices.
- ZTP decouples the configuration time of new devices from the device quantity and area distribution, which improves service provisioning efficiency.

FabricInsight-based Intelligent O&M

- The CloudEngine 6881 provides telemetry technology to collect device data in real time and send the data to Huawei data center network analyzer iMaster NCE-FabricInsight. The iMaster NCE-FabricInsight analyzes network data based on the intelligent fault identification algorithm, accurately displays the real-time network status, effectively demarcates and locates faults in a timely manner, and identifies network problems that affect user experience, accurately guaranteeing user experience.

iMaster NCE-based Simplified Network Deployment

- CloudEngine 6881 series switches can interconnect with iMaster NCE-Fabric through standard protocols such as NetConf and SNMP to implement network automatic management and control, providing more efficient and intelligent operation methods, simplifying network management, and reducing the OPEX.

FabricInsight-based Intelligent O&M

- Huawei's Packet Conservation Algorithm for Internet (IPCA) technology implements accurate per-hop packet loss, delay, and jitter detection for real service flows, locating network faults in real time.
- CloudEngine 6881 series proactively perform path detection over the entire network, periodically checking sample flows to determine the connectivity of all paths on the network and locates fault points, providing real-time network health information.
- CloudEngine 6881 series support visualization of all flows and congestion, improving service experience.

Flexible Airflow Design, Improving Energy Efficiency

Flexible front-to-back/back-to-front airflow design

- CloudEngine 6881 series use a strict front-to-back/back-to-front airflow design that isolates cold air channels from hot air channels. This design improves heat dissipation efficiency and meets design requirements of data center equipment rooms.
- Air can flow from front to back or back to front depending on the fans and power modules that are used.
- Redundant power modules and fans can be configured to ensure service continuity.

Innovative energy-saving technologies

- CloudEngine 6881 series have innovative energy-saving chips and can measure system power consumption in real time. The fan speed can be adjusted dynamically based on system consumption. These energy-saving technologies reduce O&M costs and contribute to a greener data center.

Clear Indicators, Simplifying Maintenance

Clear indicators

- Port indicators clearly show the port status and port rate. The 100GE port indicators can show the states of all ports derived from the 100GE ports.
- State and stack indicators on both the front and rear panels enable users to maintain the switch from either side.
- CloudEngine 6881 series support remote positioning. Remote positioning indicators enable users to easily identify the switches they want to maintain in an equipment room full of devices.

Simple maintenance

- The management port, fans, and power modules are on the front panel, which facilitates device maintenance.
- Data ports are located at the rear, facing servers. This simplifies cabling.

Licensing

CloudEngine 6881 supports Huawei IDN One Software (N1 mode for short) licensing mode. The CloudFabric N1 business model combines the NCE controller, analyzer, and CloudEngine switch software for use in a range of common scenarios. This simplifies transactions, provides customers with more functions and value, and protects their software investment with Software License Portability.

Product	Feature	N1 Mandatory Software Packages				N1 Add-on Software Packages
		Management	Foundation	Advanced	Premium	
CloudEngine 6881 Series Switch						Multi-cloud Multi-DC Value-added Package
	Basic software	√	√	√	√	
	IPV6	√	√	√	√	
	VXLAN	√	√	√	√	
	Lossless upgrade	√	√	√	√	
	Telemetry		√	√	√	
	NSH			√	√	
iMaster NCE-Fabric	Automatic deployment function		√	√	√	
	Basic intent functions (simulation and verification, and network-wide configuration rollback)				√	
	Multi-Cloud Multi-DC function					√
iMaster NCE-FabricInsight	Basic network analysis functions of Telemetry		√	√	√	
	Network health evaluation			√	√	
	Value-added functions for network traffic analysis (managing				√	

Product	Feature	N1 Mandatory Software Packages				N1 Add-on Software Packages
	100 VMs)					
Version Mapping		Select one from the four options. The Foundation software package contains functions of the Management software package, the Advanced software package contains functions of the Foundation software package, and the Premium software package contains functions of the Advanced software package.				It is used with the Foundation, Advanced, or Premium software package.
For details about product function differences, refer to the product documentation.						

Note: V200R005C20, V200R019C10 and later versions can support N1 mode, V200R020C00 and later versions can support Premium package.

Note: For detailed information of Huawei CloudFabric N1 Business Model, visit <https://e.huawei.com/en/material/networking/dcs/switch/03a0e69bfa2c4f168323ba94a75f1f09>

Product Specifications

Note: This content is applicable only to regions outside mainland China. Huawei reserves the right to interpret this content.

Functions and Features

Item	CloudEngine 6881-48S6CQ	CloudEngine 6881-48T6CQ
Device virtualization	iStack	
	M-LAG	
Network virtualization	VXLAN	
	BGP-EVPN	
	QinQ access VXLAN	
Data center interconnect	VXLAN mapping, implementing interconnection between multiple DCI networks at Layer 2	
SDN	iMaster NCE-Fabric	
Network convergence	PFC and ECN	
	RDMA and RoCE (RoCE v1 and RoCE v2)	
Programmability	OPS programming	
	Ansible-based automatic configuration and open-source module release	
Traffic analysis	NetStream	
	sFlow	
VLAN	Adding access, trunk, and hybrid interfaces to VLANs	
	Default VLAN	
	QinQ	
MAC address	Dynamic learning and aging of MAC address entries	
	Static, dynamic, and blackhole MAC address entries	

Item	CloudEngine 6881-48S6CQ	CloudEngine 6881-48T6CQ
	Packet filtering based on source MAC addresses	
	MAC address limiting based on ports and VLANs	
IP routing	IPv4 routing protocols, such as RIP, OSPF, IS-IS, and BGP	
	IPv6 routing protocols, such as RIPng, OSPFv3, IS-ISv6, and BGP4+	
	IP packet fragmentation and reassembly	
IPv6	VXLAN over IPv6	
	IPv6 VXLAN over IPv4	
	IPv6 Neighbor Discovery (ND)	
	Path MTU Discovery (PMTU)	
	TCP6, IPv6 ping, IPv6 tracert, IPv6 socket , UDP6, and Raw IP6	
Multicast	Multicast routing protocols such as IGMP, PIM-SM, and MBGP	
	IGMP snooping	
	IGMP proxy	
	Fast leaving of multicast member interfaces	
	Multicast traffic suppression	
	Multicast VLAN	
Reliability	Fine-grained microsegmentation isolation	
	Link Aggregation Control Protocol (LACP)	
	STP, RSTP, VBST, and MSTP	
	BPDU Guard	
	Smart Link and multi-instance	
	Device Link Detection Protocol (DLDP)	
	Hardware-based Bidirectional Forwarding Detection (BFD)	
	VRRP, VRRP load balancing, and BFD for VRRP	
	BFD for BGP/IS-IS/OSPF/Static route	
	BFD for VXLAN	
QoS	Traffic classification based on Layer 2, Layer 3, Layer 4, and priority information	
	ACL, CAR, re-marking, and scheduling	
	Queue scheduling modes such as PQ,DRR and PQ+DRR	
	Congestion avoidance mechanisms, including WRED and tail drop	
	Traffic shaping	
O&M	iPCA (Packet Conservation Algorithm for Internet)	
	Network-wide path detection	
	Telemetry	

Item	CloudEngine 6881-48S6CQ	CloudEngine 6881-48T6CQ
	ERSPAN+	
	Statistics on the buffer microburst status	
	VXLAN OAM: VXLAN ping and VXLAN tracer	
Configuration and maintenance	Console, Telnet, and SSH terminals	
	Network management protocols, such as SNMPv1/v2/v3	
	File upload and download through FTP and TFTP	
	BootROM upgrade and remote upgrade	
	Hot patches	
	User operation logs	
	Zero Touch Provisioning (ZTP)	
Security and management	Command line authority control based on user levels, preventing unauthorized users from using commands	
	Defense against DoS address attacks, ARP storms, and ICMP attacks	
	Port isolation, port security, and sticky MAC	
	Binding of the IP address, MAC address, port number, and VLAN ID	
	Authentication methods, including AAA, RADIUS, and HWTACACS	
	Remote Network Monitoring (RMON)	

Performance and Scalability

Item	CloudEngine 6881-48S6CQ	CloudEngine 6881-48T6CQ
Maximum number of MAC address entries	256K	
Maximum number of Forwarding routes (FIB IPv4/ IPv6)	256K/80K	
ARP table size	256K	
Maximum number of VRF	4096	
IPv6 ND (Neighbor Discovery) table size	80K	
Maximum Number of multicast routes (Multicast FIB IPv4/IPv6)	32K/2K	
Maximum VRRP groups	1024	
Maximum number of ECMP paths	128	
Maximum ACL number	30K	
Maximum number of broadcast domains	8K	
Maximum number of BDIF	8K	
Maximum number of tunnel endpoints (VTEP)	2K	
Maximum number of lag group	1024	
Maximum number of links in a lag group	128	

Item	CloudEngine 6881-48S6CQ	CloudEngine 6881-48T6CQ
Maximum number of MSTP instance	64	
VBST (Maximum number of VLANs where VBST can be configured)	1000	

Note: This specification may vary between different scenarios. Please contact Huawei for details.

Hardware Specifications

Item		CloudEngine 6881-48S6CQ	CloudEngine 6881-48T6CQ
Physical Features	Dimensions (W x D xH, mm)	442*420*43.6	
	Weight (excluding optical transceivers, power modules, and fan assemblies/ including AC power modules and fan assemblies, excluding optical transceivers, kg)	5.7/7.8	6.5/8.5
	Switching capacity (Tbps)	2.16	
	Forwarding performance (Mpps)	940	
25GE SFP28 ports		0	0
10GE SFP+ ports		48	0
10GE BASE-T ports		0	48
40/100GE QSFP28 ports		6	
Management interface	Out-of-band management port	1*GE management interface	
	Console port	1*RJ45 interface	
	USB port	1	
CPU	Main frequency (HZ)	1.4G	
	Number of cores	4	
Storage	RAM	4GB	
	NOR Flash	64MB	
	NAND Flash	4GB	
System	System buffer	42MB	
Power Supply System	Power modules	600W AC 1000W -48V DC 1200W 380V HVDC	
	Rated voltage range (V)	AC: 100V to 240V DC: -48V to -60V HVDC: 240V to 380V	
	Maximum voltage range (V)	AC: 90V to 290V DC: -38.4V to -72V HVDC: 190V to 400V	
	Maximum input current	AC 600W: 100V to 240V 8 A	

Item		CloudEngine 6881-48S6CQ	CloudEngine 6881-48T6CQ
		1000W -48V DC: -48 to 60V 30A 1200W 380V HVDC: 190V 8A	
	Typical power	194W (100% traffic load, copper cable, normal temperature, dual power modules) 240W (100% traffic load, short-distance optical transceivers, normal temperature, dual power modules)	347 W (100% traffic load, 3 m network cables and copper cables, normal temperature, dual power modules) 362 W (100% traffic load, 3 m network cables and short-distance optical modules, normal temperature, dual power modules)
	Maximum power	349W	452W
	Frequency (AC, HZ)	50/60	50/60
Heat Dissipation	Heat dissipation mode	Air cooling	
	Number of fan trays	4	
	Heat dissipation airflow	Front-to-back or back-to-front airflow	
	Maximum heat consumption (BTU/hr)	1191	1542
Environment specifications	Long-term operating temperature (°C)	0°C to 40°C (0-1800m) The temperature decreases by 1°C each time the altitude increases by 220 m.	
	Storage temperature (°C)	-40°C to +70°C	
	Relative humidity	5% to 95%	
	Operating altitude (m)	Up to 5000	
	Sound power at 27°C (dBA)	Front-to-back airflow: < 67 Back-to-front airflow: < 66	Front-to-back airflow: < 68 Back-to-front airflow: < 67
	Sound power at 40°C (dBA)	Front-to-back airflow: < 84 Back-to-front airflow: < 83	Front-to-back airflow: < 85 Back-to-front airflow: < 84
	Sound pressure at 27°C (dBA)	Front-to-back airflow: 53 in average (maximum: 58) Back-to-front airflow: 52 in average (maximum: 57)	Front-to-back airflow: 54 in average (maximum: 59) Back-to-front airflow: 53 in average (maximum: 58)
	Surge protection	AC power supply protection: 6 kV in common mode and 6 kV in differential mode DC power supply protection: 4 kV in common mode and 2 kV in differential mode	

Item		CloudEngine 6881-48S6CQ	CloudEngine 6881-48T6CQ
Reliability	MTBF (year)	45.90	48.16
	MTTR (hour)	1.57	1.78
	Availability	0.9999960856	0.9999953209

Note: For detailed information of CloudEngine 6800 Platform hardware information, visit <https://support.huawei.com/enterprise/en/doc/EDOC1000019246?idPath=7919710%7C21782165%7C21782239%7C22318540%7C7597815>

Safety and Regulatory Compliance

The following table lists the safety and regulatory compliance of CloudEngine 6800 series switches.

Certification Category	Description
Safety	<ul style="list-style-type: none"> • EN 60950-1 • EN 60825-1 • EN 60825-2 • UL 60950-1 • CSA-C22.2 No. 60950-1 • IEC 60950-1 • AS/NZS 60950-1 • GB4943
Electromagnetic Compatibility (EMC)	<ul style="list-style-type: none"> • EN 300386 • EN 55032: CLASS A • EN 55024 • IEC/EN 61000-3-2 • IEC/EN 61000-3-3 • FCC 47CFR Part15 CLASS A • ICES-003: CLASS A • CISPR 32: CLASS A • CISPR 24 • AS/NZS CISPR32 • VCCI- CISPR32: CLASS A • GB9254 CLASS A
Environment	<ul style="list-style-type: none"> • 2011/65/EU EN 50581 • 2012/19/EU EN 50419 • (EC) No.1907/2006 • GB/T 26572 • ETSI EN 300 019-1-1 • ETSI EN 300 019-1-2 • ETSI EN 300 019-1-3 • ETSI EN 300 753 GR63

Note

EMC: electromagnetic compatibility

CISPR: International Special Committee on Radio Interference

EN: European Standard

ETSI: European Telecommunications Standards Institute

CFR: Code of Federal Regulations

FCC: Federal Communication Commission

IEC: International Electrotechnical Commission

AS/NZS: Australian/New Zealand Standard

VCCI: Voluntary Control Council for Interference

UL: Underwriters Laboratories

CSA: Canadian Standards Association

Supported MIBs

For details about the MIB information, visit <https://support.huawei.com/enterprise/en/switches/cloudengine-6800-pid-7597815>

Optical Transceivers and Cable

For details about the optical transceivers and cables information, visit <https://e.huawei.com/en/material/networking/dcs/switch/f6d91cf16df0474998087676a33fd41e>

Ordering Information

Mainframe	
CE6881-48S6CQ	CE6881-48S6CQ switch (48*10G SFP+, 6*100G QSFP28, without fan and power modules)
CE6881-48S6CQ-B	CE6881-48S6CQ-B switch (48*10G SFP+, 6*100G QSFP28, 2*AC power modules, 4*fan modules, port-side intake)
CE6881-48S6CQ-F	CE6881-48S6CQ-F switch (48*10G SFP+, 6*100G QSFP28, 2*AC power modules, 4*fan modules, port-side exhaust)
CE6881-48T6CQ	CE6881-48T6CQ switch (48*10G RJ45, 6*100G QSFP28, without fan and power modules)
CE6881-48T6CQ-B	CE6881-48T6CQ-B switch(48*10GE RJ45,6*100GE QSFP28,2*AC power modules,4*fan modules,port-side intake)
CE6881-48T6CQ-F	CE6881-48T6CQ-F switch (48*10G RJ45, 6*100G QSFP28, 2*AC power modules, 4*fan modules, port-side exhaust)

Fan Tray

Model	Description	Applicable Product
FAN-031A-F	Fan box (F,FAN panel side intake)	CloudEngine 6881 series
FAN-031A-B	Fan box (B,FAN panel side exhaust)	CloudEngine 6881 series

Power

Model	Description	Applicable Product
PAC600S12-CF	600W AC Power Module(Front to Back,Power panel side intake)	CloudEngine 6881 series
PAC600S12-CB	600W AC Power Module(Back to Front, Power panel side exhaust)	CloudEngine 6881 series

Model	Description	Applicable Product
PDC1000S12-DF	1000W DC Power Module (Front to Back,Power panel side intake)	CloudEngine 6881 series
PDC1000S12-DB	1000W DC Power Module (Front to Back,Power panel side exhaust)	CloudEngine 6881 series
PHD1K2S12-DB	1200W HVDC Power Module (Back to Front, Power panel side exhaust)	CloudEngine 6881 series

Software	
N1-CE68LIC-CFMM	N1-CloudFabric Management SW License for CloudEngine 6800
N1-CE68CFMM-SnS1Y	N1-CE68CFMM-SnS1Y,N1-CloudFabric Management SW License for CloudEngine 6800
N1-CE68LIC-CFFD	N1-CloudFabric Foundation SW License for CloudEngine 6800
N1-CE68CFFD-SnS1Y	N1-CloudFabric Foundation SW License for CloudEngine 6800-SnS-Year
N1-CE68LIC-CFAD	N1-CloudFabric Advanced SW License for CloudEngine 6800
N1-CE68CFAD-SnS1Y	N1-CloudFabric Advanced SW License for CloudEngine -SnS -Year
N1-CE68LIC-CFPM	N1-CloudFabric Premium SW License for CloudEngine 6800
N1-CE68CFPM-SnS1Y	N1-CloudFabric Premium SW License for CloudEngine 6800 -SnS-Year

Networking and Application

Data Center Applications

On a typical data center network, CloudEngine 6881 switches work as TOR switches and connect to CloudEngine16800, CloudEngine 12800 or CloudEngine 8800 core switches using 40GE/100GE ports, building an end-to-end 100GE full-mesh network. The core and TOR switches use fabric technologies such as VXLAN to build a non-blocking large Layer 2 network, which allows for large-scale VM migration and flexible service deployment.

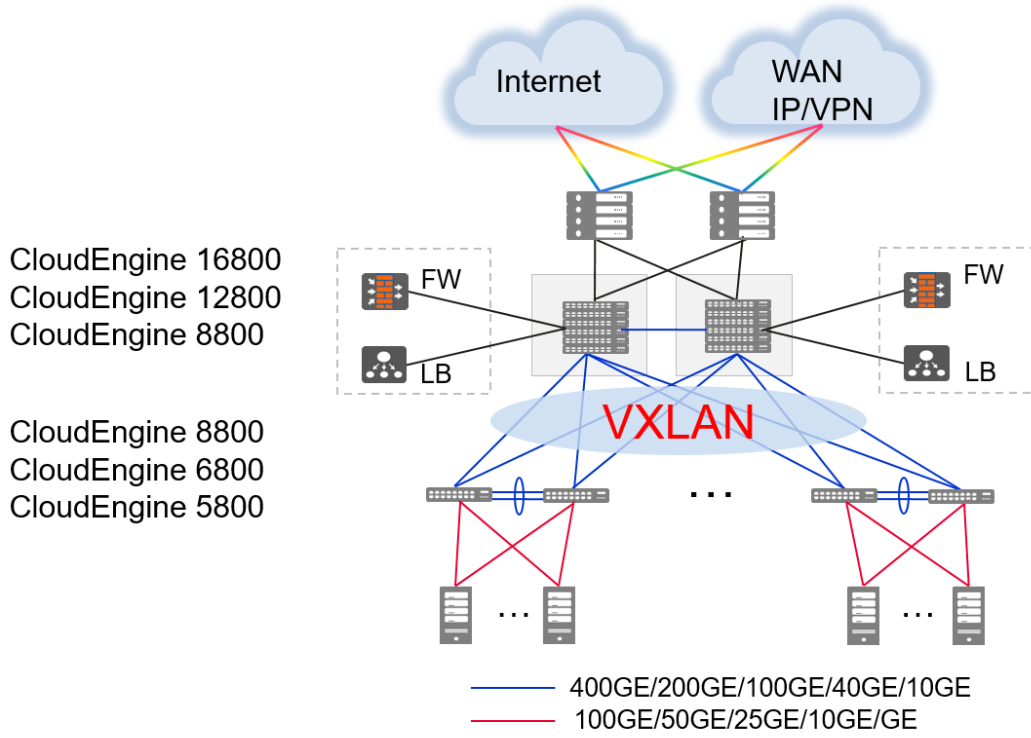

Note: VXLAN can also be used on campus networks to support flexible service deployment in different service areas.

Copyright © Huawei Technologies Co., Ltd. 2021. All rights reserved.

No part of this document may be reproduced or transmitted in any form or by any means without prior written consent of Huawei Technologies Co., Ltd.

Trademarks and Permissions



HUAWEI and other Huawei trademarks are trademarks of Huawei Technologies Co., Ltd.

All other trademarks and trade names mentioned in this document are the property of their respective holders.

Notice

The purchased products, services and features are stipulated by the contract made between Huawei and the customer. All or part of the products, services and features described in this document may not be within the purchase scope or the usage scope. Unless otherwise specified in the contract, all statements, information, and recommendations in this document are provided "AS IS" without warranties, guarantees or representations of any kind, either express or implied.

The information in this document is subject to change without notice. Every effort has been made in the preparation of this document to ensure accuracy of the contents, but all statements, information, and recommendations in this document do not constitute a warranty of any kind, express or implied.

Huawei Technologies Co., Ltd.

Address: Huawei Industrial Base Bantian, Longgang Shenzhen 518129 People's Republic of China

Website: www.huawei.com