

HARGON 351

Line extender amplifier, 1 active output, 1.2 GHz/ 200 MHz

RF PARAMETERS

Forward Channel

Bandwidth	85...258 -1218 MHz
Gain @1.2 GHz	40 ± 1 dB
Noise figure ¹	< 4.5 dB
Flatness ²	± 0.75 dB
Output level ³ :	
CTB ≤ - 60 dBc	114 dBμV
CSO ≤ - 60 dBc	114 dBμV
Digital Output level ⁴	
CINR = 41.5 dB	108 dBμV
Input testpoint (bi-directional)	- 20 ± 1.0 dB
Output testpoints (directional)	- 20 ± 0.5 dB

Reverse Channel

Bandwidth	5 -65...204 MHz
Gain	26 dB ± 1 dB
Noise figure ⁵	< 6.5 dB
Flatness ⁶	± 0.75 dB
NPR / Dynamic range ⁷	50 dB / 23 dB

OTHERS

Voltage range: remote powering	30 - 65 V AC
Max. current for RF ports / AC IN	8A / 8A
Return loss ⁸	> 18 dB
Power consumption	< 13.5 W
Operation temperature range	- 40 - 60 °C
Connectors	3 x PG11
Protection class	IP 67
Dimensions (W x L x H)	218 x 204 x 87 mm
Weight	1.5 kg

AVAILABLE VERSIONS

HARGON 351 089Y	remote powering
-----------------	-----------------



1.2 GHz technology

An extended bandwidth in downstream up to 1.2 GHz; DOCSIS 3.1 standard compliant



200 MHz technology

A possibility of extending bandwidth in upstream up to 200 MHz



VIG (VECTOR INGRESS GUARD)

System compliant; Verification and elimination of the source of ingress in the network



JXP configuration

A simple and cost-effective configuration of devices with the plug-in modules

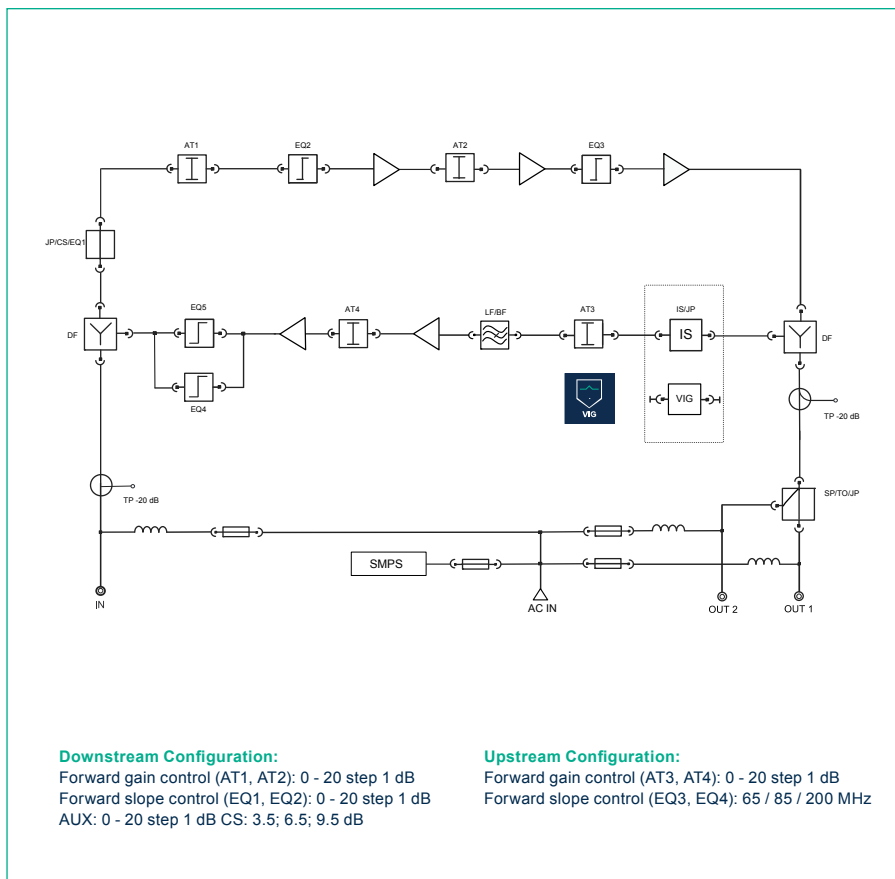

1. Typical value up to 1 GHz; 6.5 dB up to 1.2 GHz
2. Valid after starting frequency 10% above DF roll off and up to 1218 MHz
3. Typical value. According to EN50083-3, 9 dB interstage slope, 42 channels CENELEC.
4. Full digital load 258 - 1218 MHz, 120 channels QAM 256, 12 dB slope
5. Typical value up to f = 204 MHz
6. For 5 - 60 MHz with DF 65 - 85 T
7. NPR @ -9 dBμV / Hz, measured 5 - 204 MHz with 60 MHz loading
8. In 5 - 65 MHz: 18 dB for f ≤ 40 MHz, 18 dB -1.5 dB / oct for f > 40 MHz, but not worse than 11 dB

Unless otherwise specified, the whole specifications are tested with 65 / 85 duplex filters installed; at room temperature 25°C and present typical values.

21/03/2016 Specifications are subject to change without notice.