

HARGON 3810

Trunk / distribution amplifier, 3 active outputs, 1.2 GHz / 200 MHz

RF PARAMETERS

Forward Channel

Bandwidth	85...258 - 1218 MHz
Gain @1.2 GHz TRUNK / DISTRIBUTION	3 x 35 / 44 ±0.5 dB
Noise figure ¹	< 7.5 dB
Flatness TRUNK / DISTRIBUTION	±0.75 dB
Output level: ²	
CTB ≤ -60 dBc	3 x 118 dBμV
CSO ≤ -60 dBc	3 x 120 dBμV
Umax ³	3 x 112 dBμV
Input testpoint (directional)	-20 ±1.0 dB
Output testpoints (directional)	-20 ±0.75 dB

Reverse Channel

Bandwidth	5 - 65...204 MHz
Gain @204 MHz	3 x 25 ±0.75 dB
Noise figure ⁴	< 10 dB
Flatness	±0.5 dB
NPR / Dynamic range ⁵	47 dB / 25 dB

OTHERS

Voltage range:	
remote powering	30 - 65 V AC
Max. current for RF / AC IN ports	10 / 16 A
HUM modulation ⁶	≤ -62 for 7 A
Return loss ⁷	> 18 dB
Power consumption ⁸	53 W
Operation temperature range	-40 - 60 °C
RF Connectors	4 x 5/8"
Protection class	IP 67
ESD protection	4 kV
Surge protection	6 kV
Dimensions (W x L x H)	255 x 234 x 128 mm
Weight	4 kg

AVAILABLE VERSIONS

HARGON 3810 079Y	remote powering
------------------	-----------------



1.2 GHz technology
An extended bandwidth in downstream up to 1.2 GHz; DOCSIS 3.1 standard compliant



200 MHz technology
A possibility of extending bandwidth in upstream up to 200 MHz



GaN Technology
The Output parameters for analog and digital carriers improved for lower power consumption



Electronic control
A quick and uninterrupted device configuration



VMC (VECTOR Mobile Commander)
Convenient and user-friendly configuration through mobile devices

OPTIONAL



Spectrum Analyzer
Offers visibility over the whole frequency bandwidth



Auto Alignment
Self configuration based on optimal amplifier settings



VIG (VECTOR Ingress Guard)
System compliant; Verification and elimination of the source of ingress in the network



ALSAC (Automatic Level and Slope Control)
Flat and stable Output characteristics due to the compensation of temperature changes in the cables.

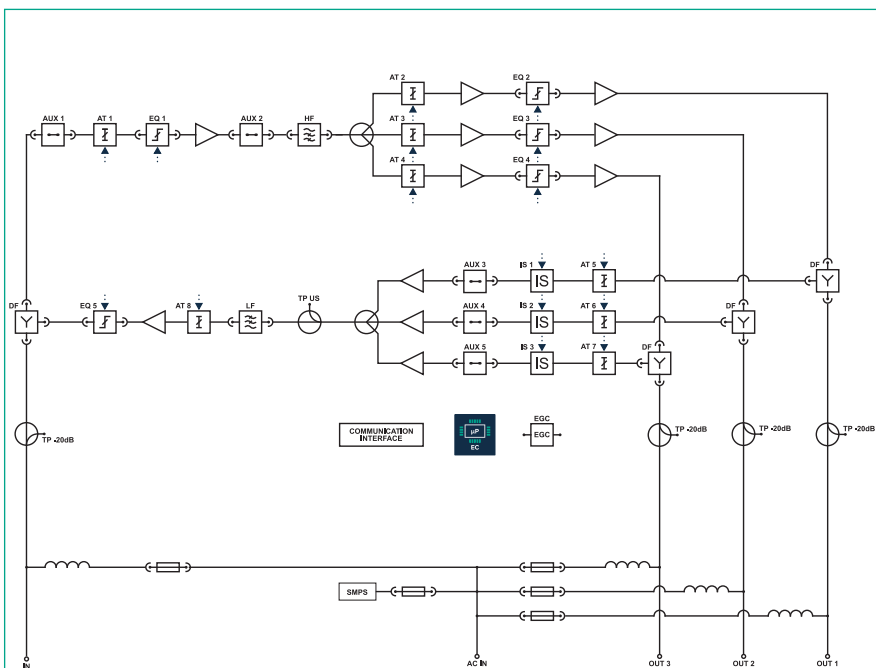

Downstream Configuration:

Input/Interstage gain control (AT1, AT2, AT3, AT4): 0 - 20, step 0.5 dB
Input/Interstage slope control (EQ1, EQ2, EQ3, EQ4, EQ5): 0 - 18, step 0.5 dB

Upstream Configuration:

Output/Interstage gain control (AT5, AT6, AT7, AT8): 0 - 20, step 0.5 dB
Output slope control (EQ4): 0 - 18, step 0.5 dB
Ingress switches (IS1, IS2, IS3): 0, -6, -40 dB

- 7.5 dB - 750 MHz; 8.0 dB - from 750 MHz to 950 MHz; 9.0 dB - from 950 MHz to 1218 MHz
- According to EN50083-3, 9 dB interstage slope between 85 - 862MHz, 42 channels CENELEC
- 110 ch 256 QAM, pre-FEC BER 10-9, 9 dB slope between 258 and 1218 MHz
- @204 MHz +1 dB
- NPR @ -9 dBμV / Hz, measured 5 - 204 MHz with 180 MHz loading, 5 dB interstage attenuator
- For $f > 15 \text{ MHz} < f < 1 \text{ GHz}$
- 18 dB for $f \leq 40 \text{ MHz}$, 18 dB -1.5 dB / oct for $f > 40 \text{ MHz}$, but not worse than 12 dB
- For 65 V AC

Unless otherwise specified, the whole specifications are tested with 65 / 85 diplex filters installed, at room temperature 25°C and present typical values.